



TriMark®

050-0550 Family Cycle Test Report

Company: TriMark Corporation
Address: 500 Bailey Ave
New Hampton, Ia. 50659

Product Code: 050-0550 (Single Rotary Mini-Latch)

Reference Test Document: ET23116C

Date Tested: 3/19/24 thru 12/9/24

PICTURE IS FOR REFERENCE ONLY



DISCLAIMERS

This document is intended to provide a general overview of elements that affect cycle life and the performance of TriMark's single rotary mini latch. In no way is it intended to guarantee the performance of such a product in the customer's particular application.

TriMark recognizes that applications of this latch may fall within the requirements of FMVSS 206 and SAE J839 safety standards for on-road and off-road operator entrance doors.

These safety related requirements are dependent on door application, e.g. front and rear hinged doors, sliding doors, or hinged upward swinging doors. The entire door hardware system must be included in the design/analysis process: latch, handle, lock mechanism, rods/linkages, fasteners, hinges, etc. This ensures compatibility of all components within the hardware system. If FMVSS 206 is a requirement, then all the components within the door system must comply with strength, inertia and locking requirements as specified within the Standard.

TriMark assumes no liability for application of latches within systems which are designed, validated, and produced without the involvement of TriMark engineering. It must also be noted that both FMVSS206 and SAEJ839 are standards intended to cover entire SYSTEMS and as such the latch is merely a component of that system and shall not be construed to be a system within itself.

Customers applying TriMark product must take into account a myriad of factors to ensure proper life cycle and performance of the door entry system. TriMark encourages customers to seek the assistance of our professional Engineering Staff for details and assistance in applying our products to their needs.

Table of Contents

1. General Information

1.1. Description of Product	4
-----------------------------------	---

2. Factors for Success

2.1. List of Factors... ..	5
----------------------------	---

3. Test Information

3.1. Test Equipment.	5
---------------------------	---

3.2. Laboratory Ambience Condition	5
--	---

3.3. Test Condition	5
---------------------------	---

3.4. Results and Observations.....	6
------------------------------------	---

3.4.1. Cycle test Results	6-7
---------------------------------	-----

3.4.2. Average Release Efforts.....	8-31
-------------------------------------	------

3.5. Technical Product Information	32
--	----

The information contained in this document is the property of TriMark Corporation and is for general guidance only for a particular subject(s) and is not fully comprehensive of such subject(s). This document and its details may not be copied, used or disclosed for any reason except as authorized by TriMark Corporation. We endeavor to keep the information up-to-date and correct and we make no representations or warranties of any kind, express or implied, about the completeness, accuracy, reliability, suitability or availability with respect to this information.

It is recommended that the user contact TriMark prior to making an engineering or purchasing decision to confirm and verify the information and that the product will perform as intended in the respective application.

1. General Information

1.1 Description of Product

Manufacturer: TriMark Corporation

Product Name: 050-0550, single rotary mini latch assembly

Sample Quantity: 20

Failure Criteria: When the rotor and catch will no longer engage

When the latch cannot hold the striker bolt load exerted by the test equipment

When the latch will not run beyond 100 cycles without adjustment

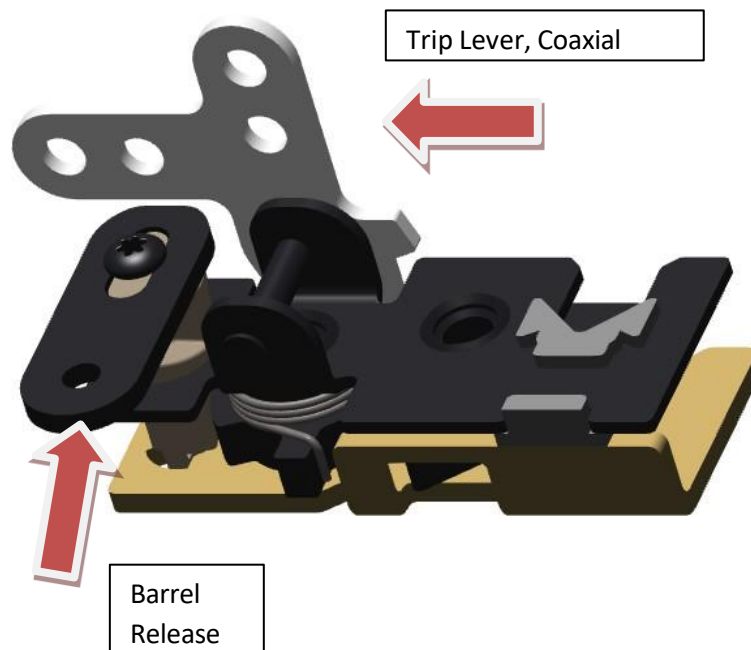

2. Factors for Success

2.1 List of Factors

- Minimize Striker Bolt Load (**SBL**) throughout life of system
 - Take into account door seal loads
- Striker bolt alignment
 - Maintain proper control of installation alignment
 - Design for minimum hinge sag over time
 - Account for both centerline and axial alignment in design planning
 - For Proper alignment of striker please download Striker Installation pdf document on TriMark website. www.trimarkcorp.com
- Environmental conditions of the system
 - Minimize dust and dirt ingress
 - Minimize moisture ingress
- Weight of the door and how the door is supported.
 - Latch is designed to keep door closed, it is not designed to support the door
 - Design for minimum hinge sag over time
 - Welding on or near latches during installation is PROHIBITED and will cause premature failure of critical internal components
- Properly **Torque** mounting fasteners during installation
- Properly lubricate moving components throughout life of product

3. Test Information

(Testing was done in test department environment and results in actual application may show different results)

3.1 Test Equipment

Bench Cycle Test Equipment

3.2 Laboratory Ambience Condition

70°F ambient temperature

3.3 Test Condition

Fixture simulated proper Strike Bolt alignment

No dust or dirt added to test environment

3.4 Results and Observations

It is observed from this testing that the latch can withstand a high cycle count at a 50 lb. striker bolt load meeting a R95C80 level.

3.4.1 Cycle Test Results

Example	SBL (lb)	SBL (kg)	Cycle count
1	50	22.68	463,832
2	50	22.68	434,614
3	50	22.68	428,653
4	50	22.68	428,653
5	50	22.68	428,653
6	50	22.68	428,653
7	50	22.68	428,653
8	50	22.68	428,653
9	50	22.68	428,653
10	50	22.68	428,653
11	50	22.68	428,653
12	50	22.68	428,653
13	50	22.68	428,653
14	50	22.68	428,653
15	50	22.68	428,653
16	50	22.68	428,653
17	50	22.68	428,653
18	50	22.68	428,653
19	50	22.68	428,653
20	50	22.68	428,653

One cycle represents striker engaging latch – release from inside, then striker engaging latch again and releasing from outside release. Thus, if the latch reaches 100,000 total cycles, then each release lever (inside and outside) achieved 50,000 cycles each.

Lubrication

Products manufactured by *TriMark* are lubricated and shipped with the minimum amount of lubrication to function correctly when they leave the factory. Many products have a dry-type solid film lubricant applied that will give years of trouble free performance; however, mechanical products do require maintenance and periodic lubrication. The application of a quality lubricant such as Cen-Pe-Co or its equivalent, will maintain the quality and performance of the *TriMark* products.

Please note by adding a lubricant to the latch it will increase the chance of the lubricant picking up contaminants such dust and dirt. These contaminants can cause adverse affects to the performance/life of the latch.

3.4.2 Average Release Efforts

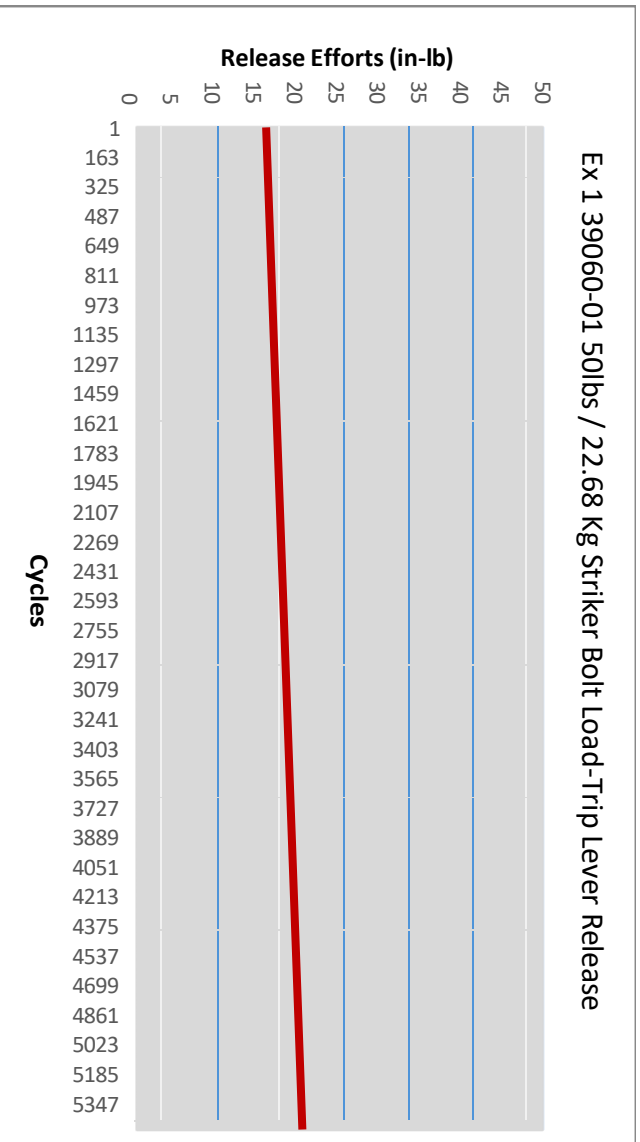
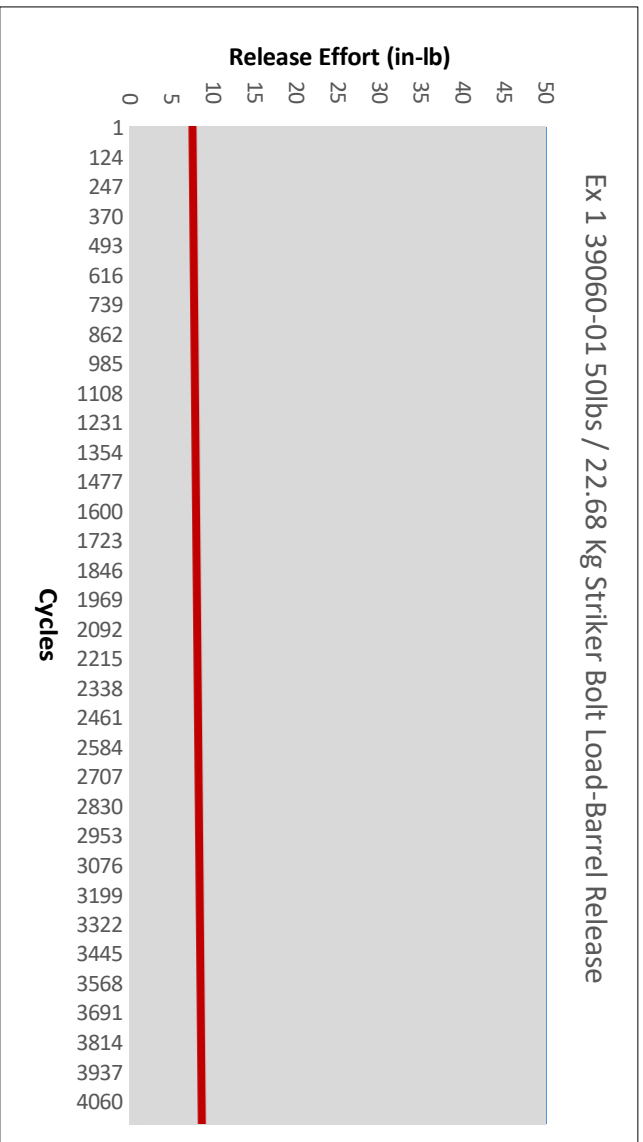

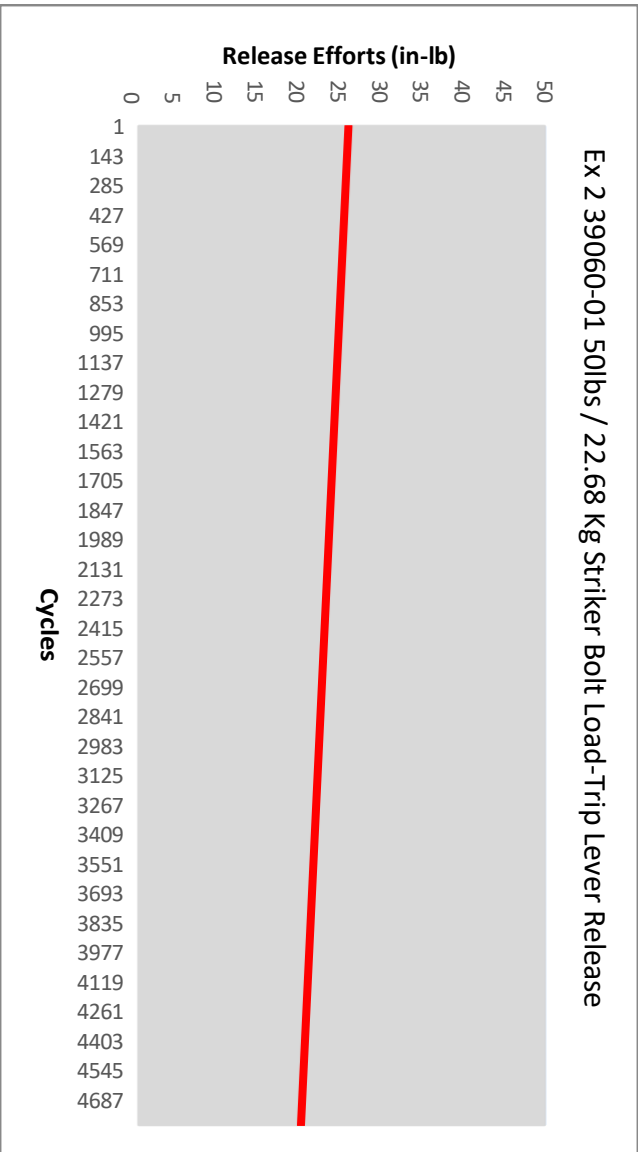
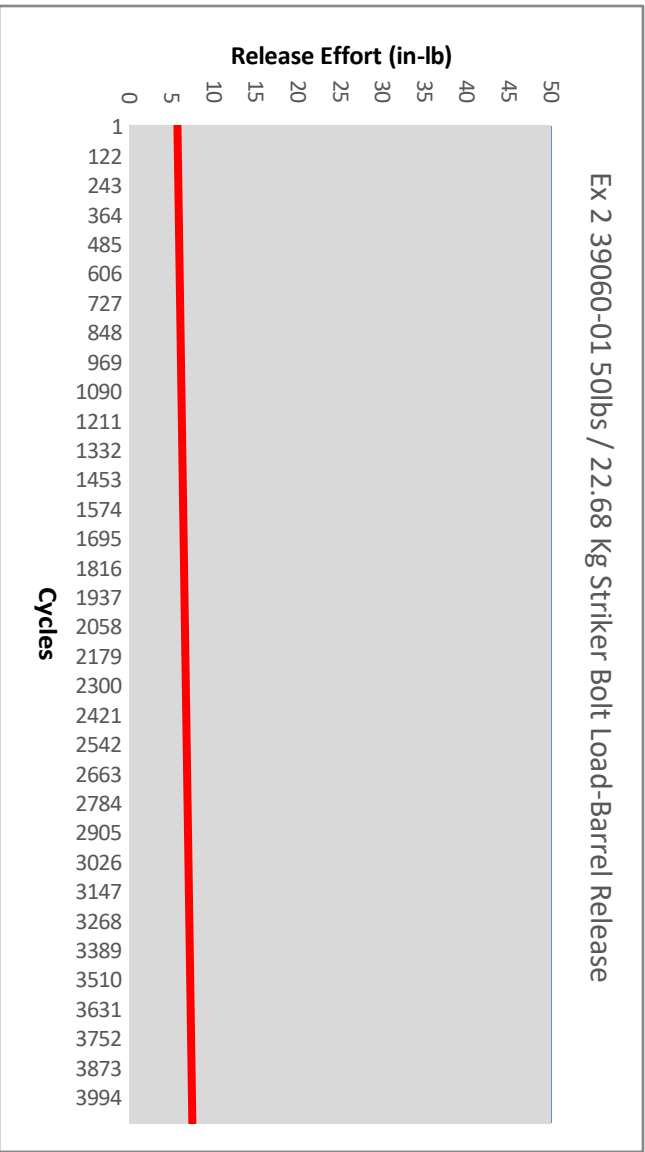

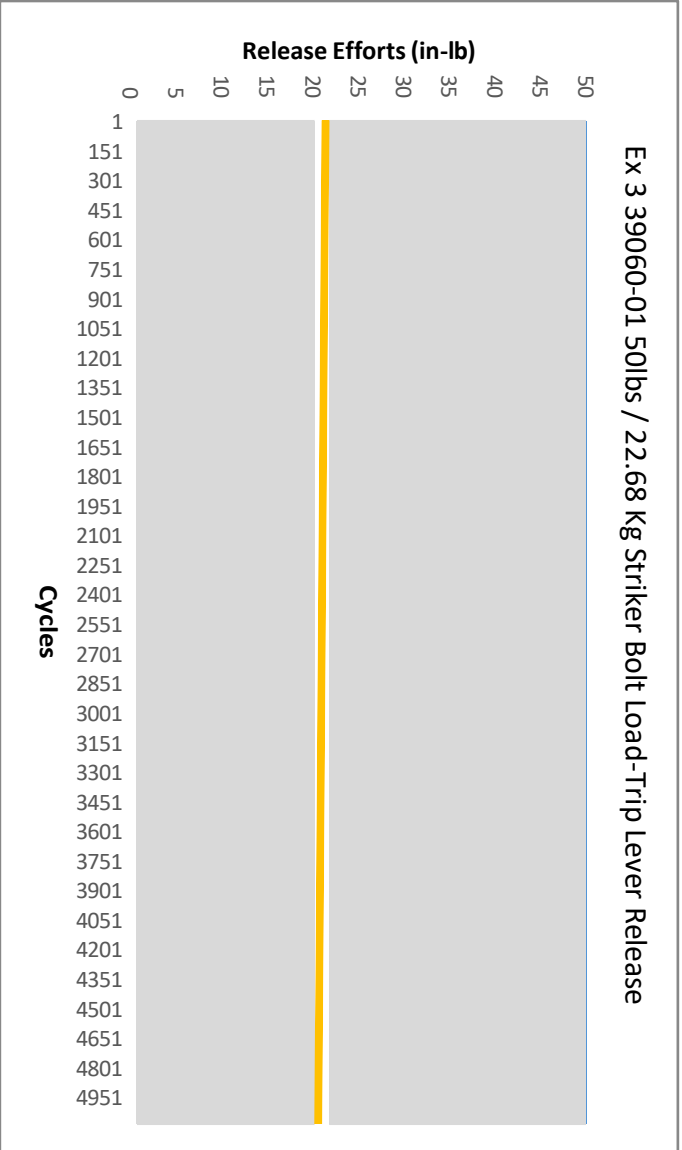
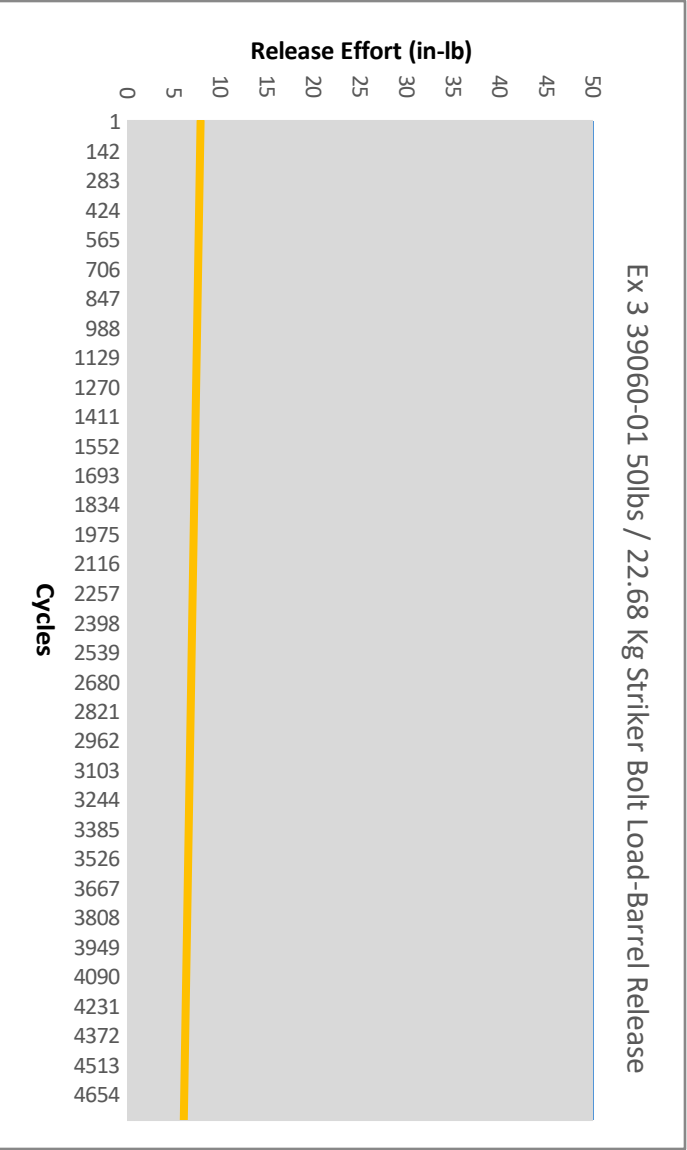

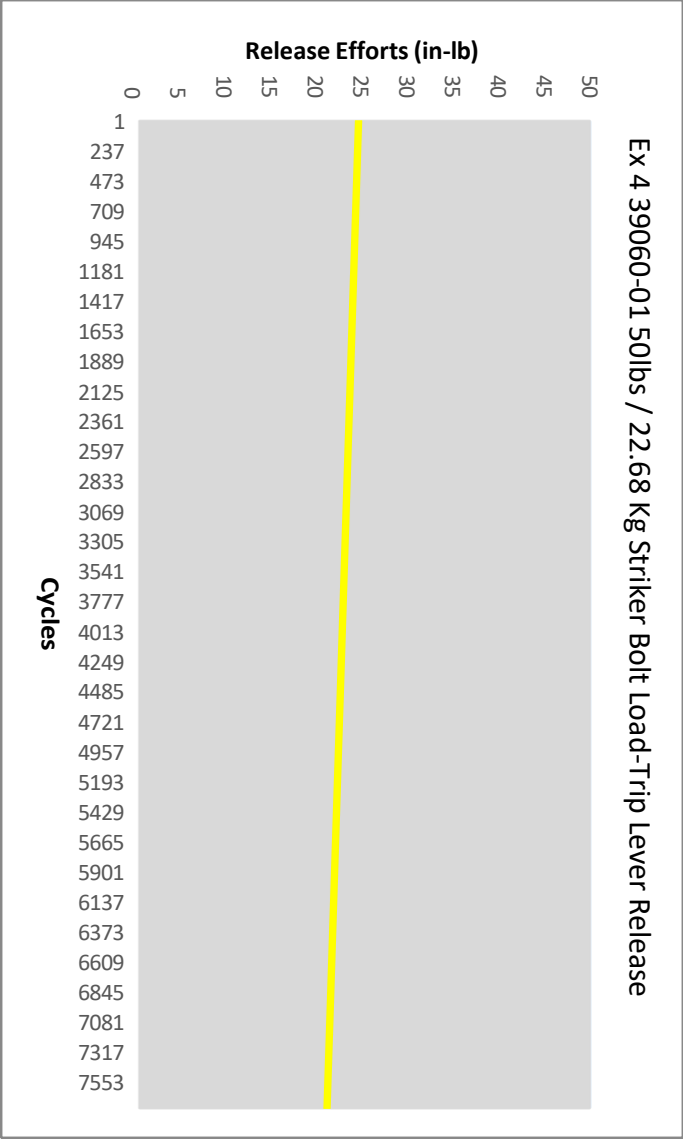
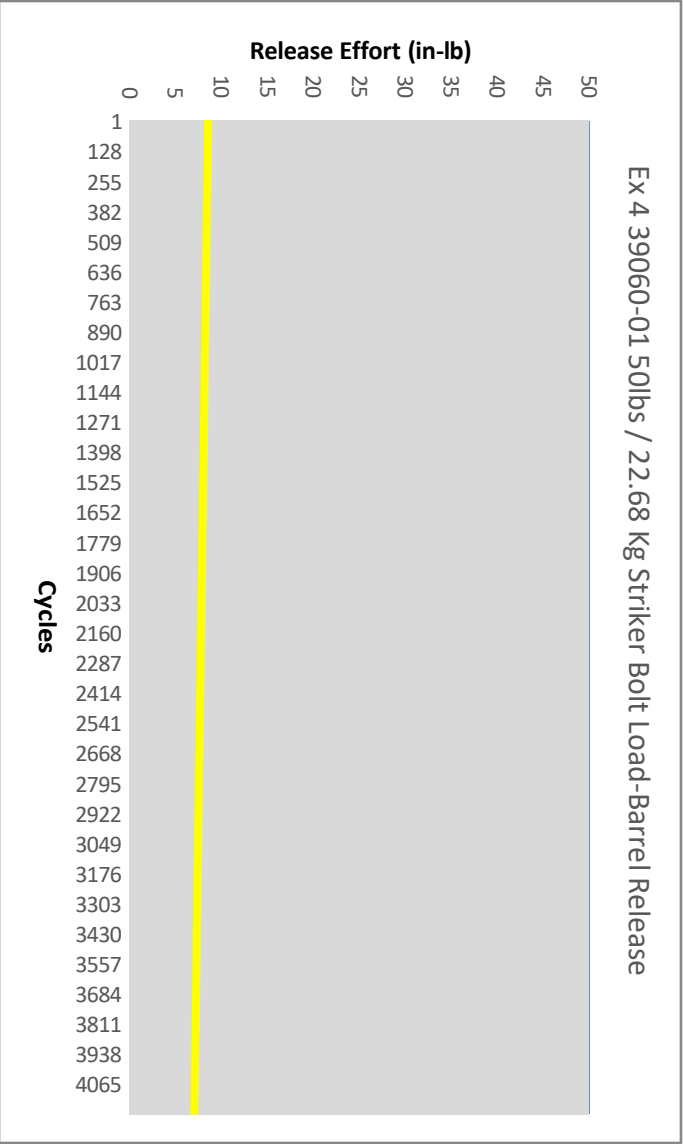

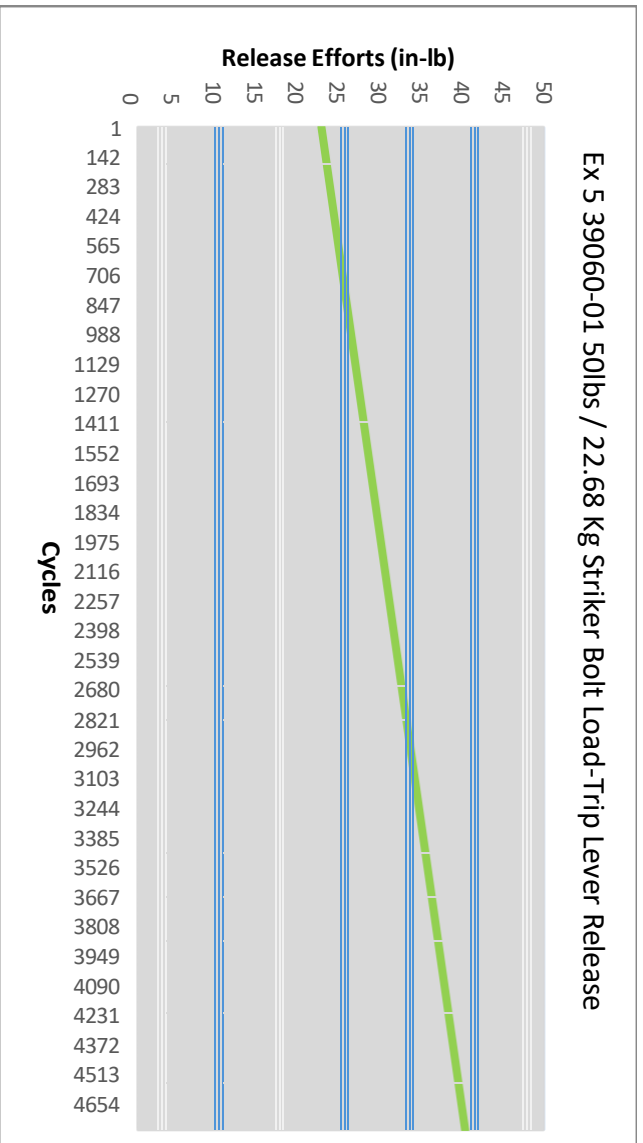
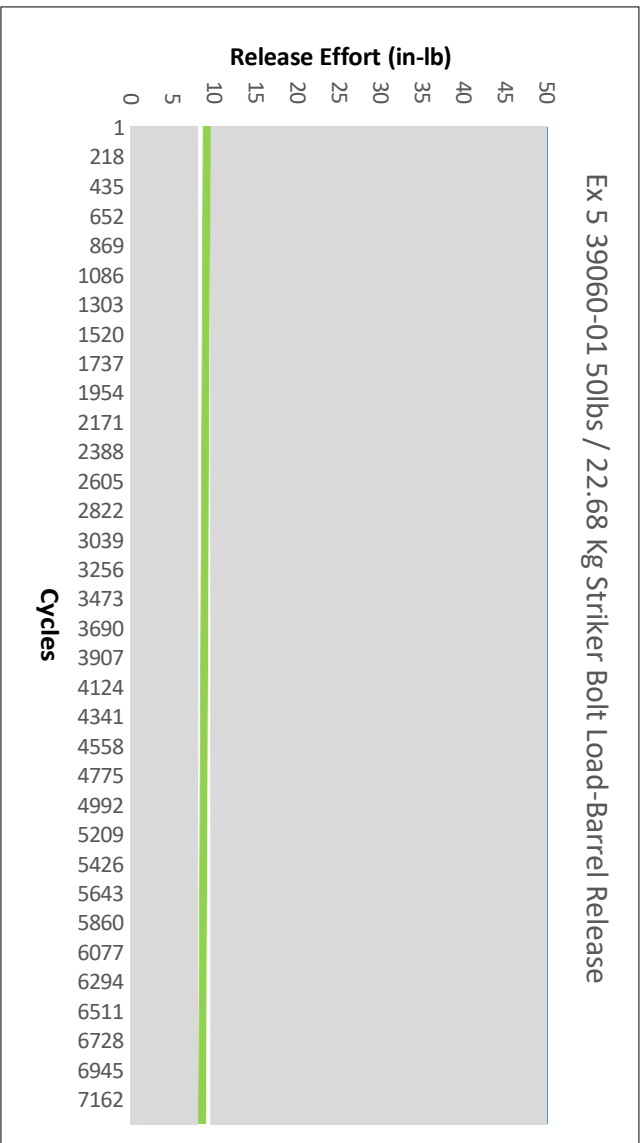

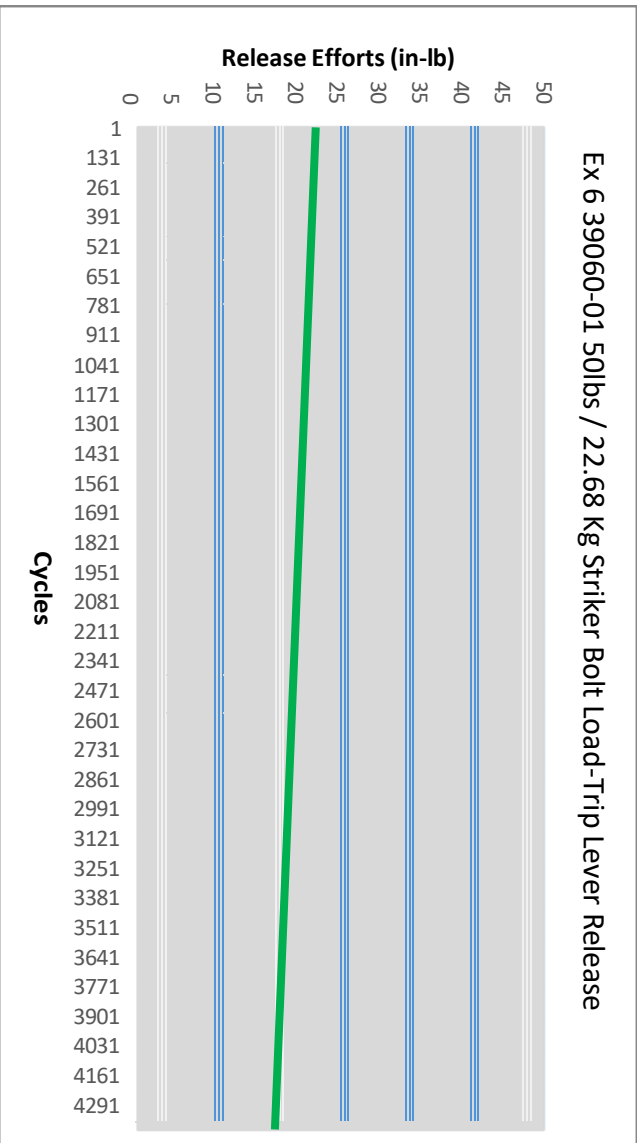
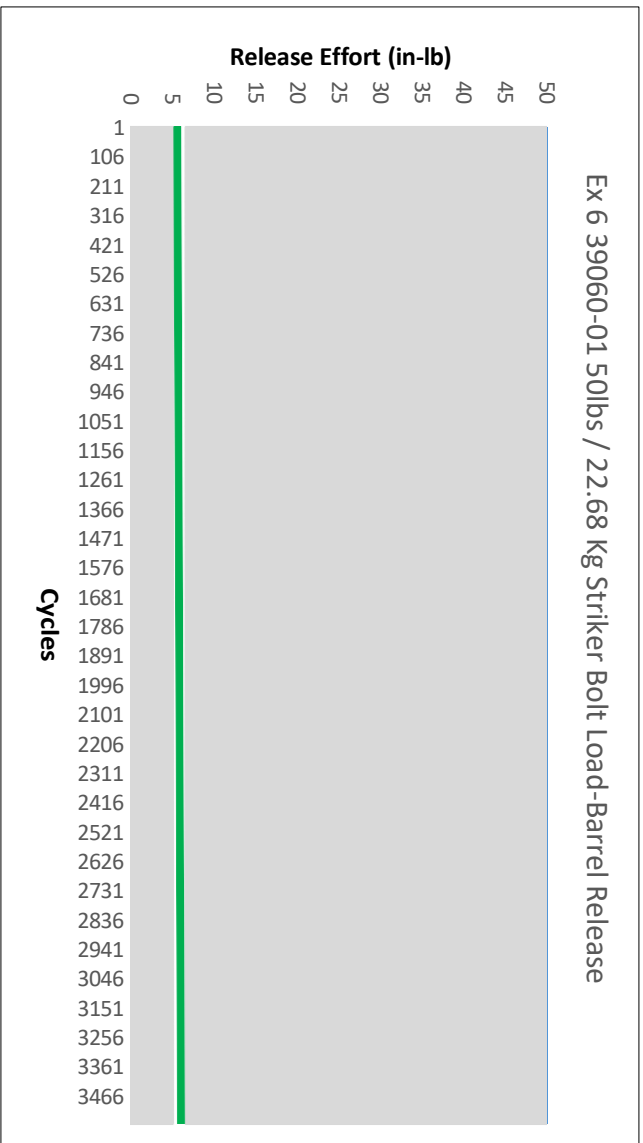

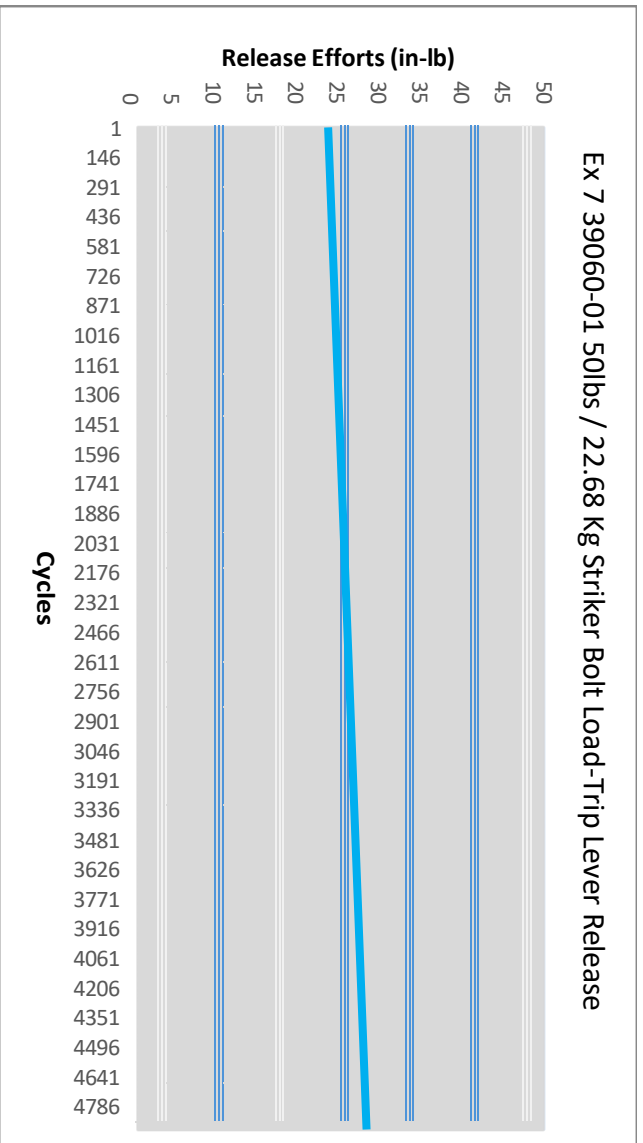
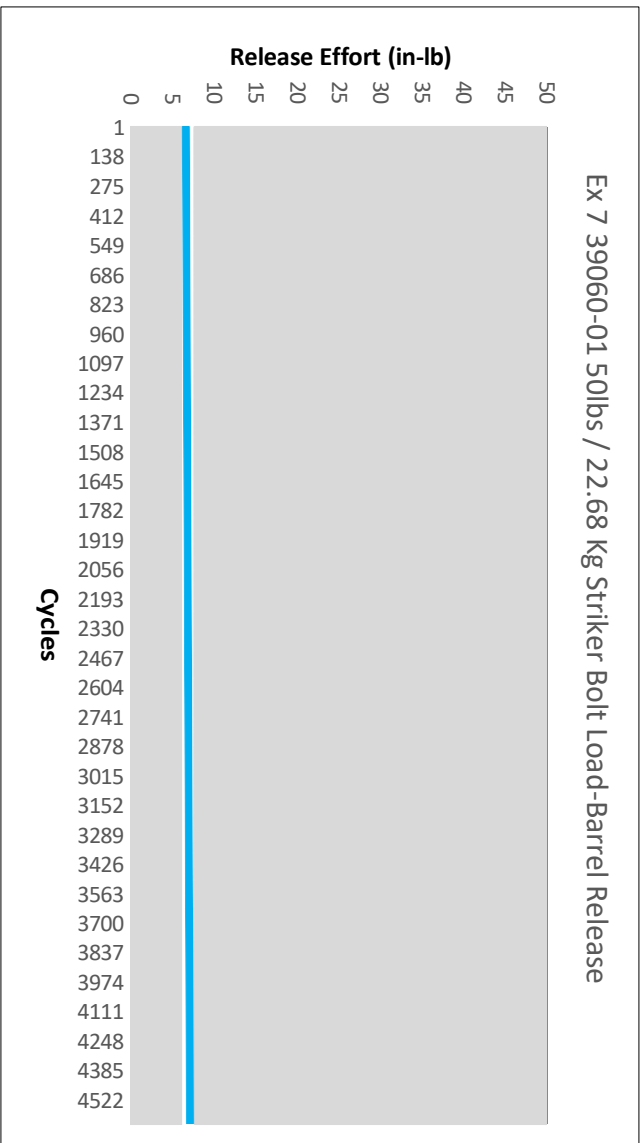

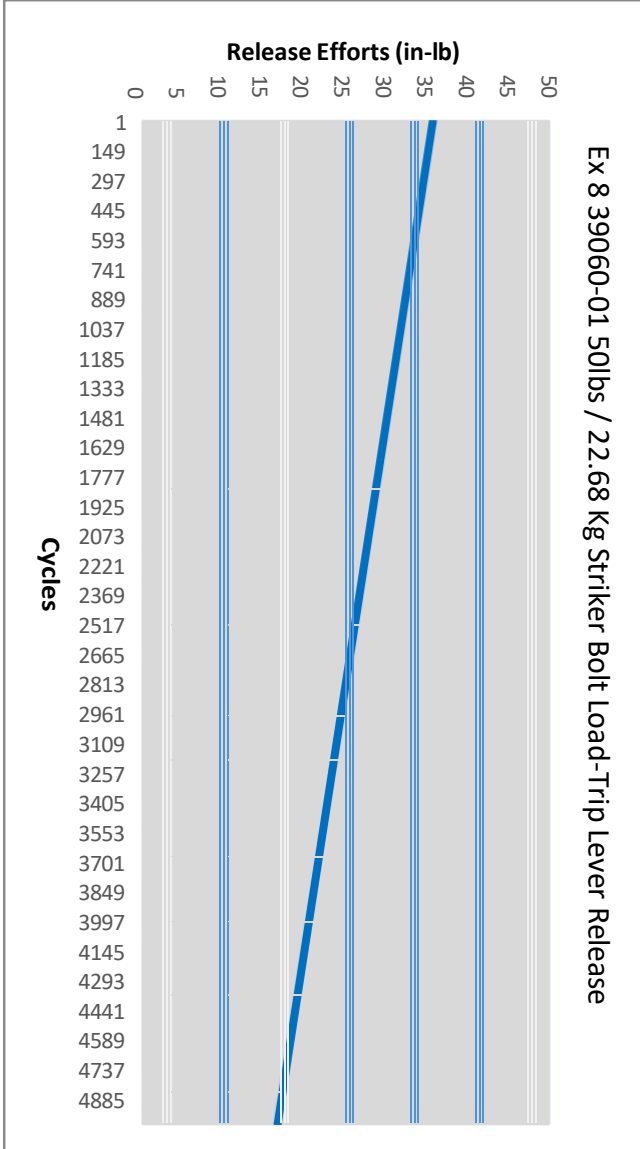
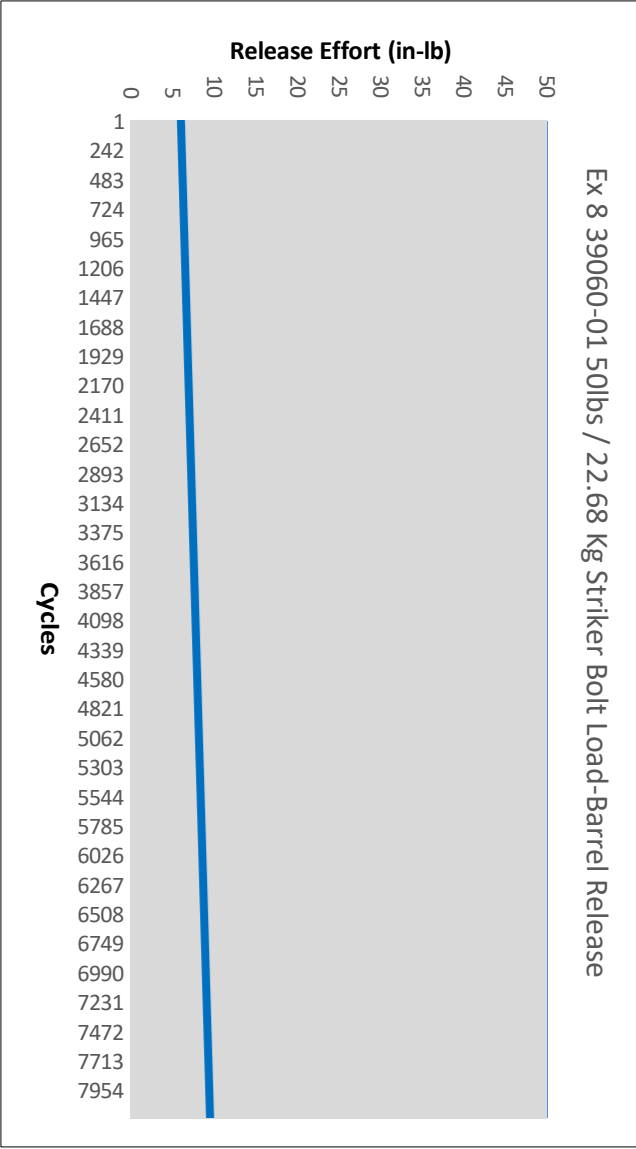

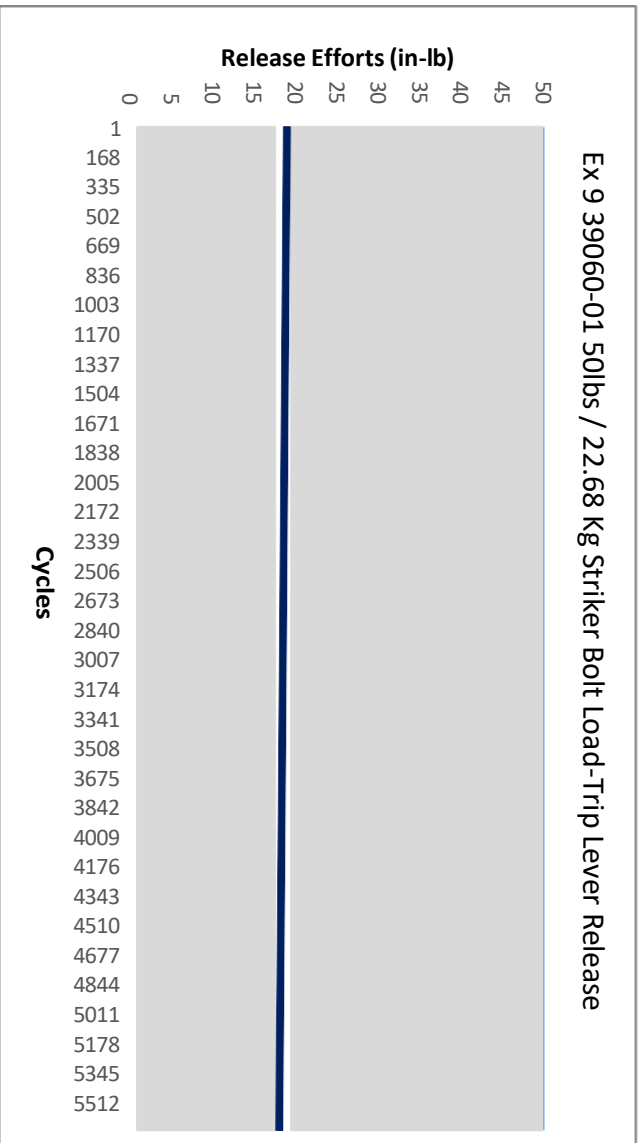
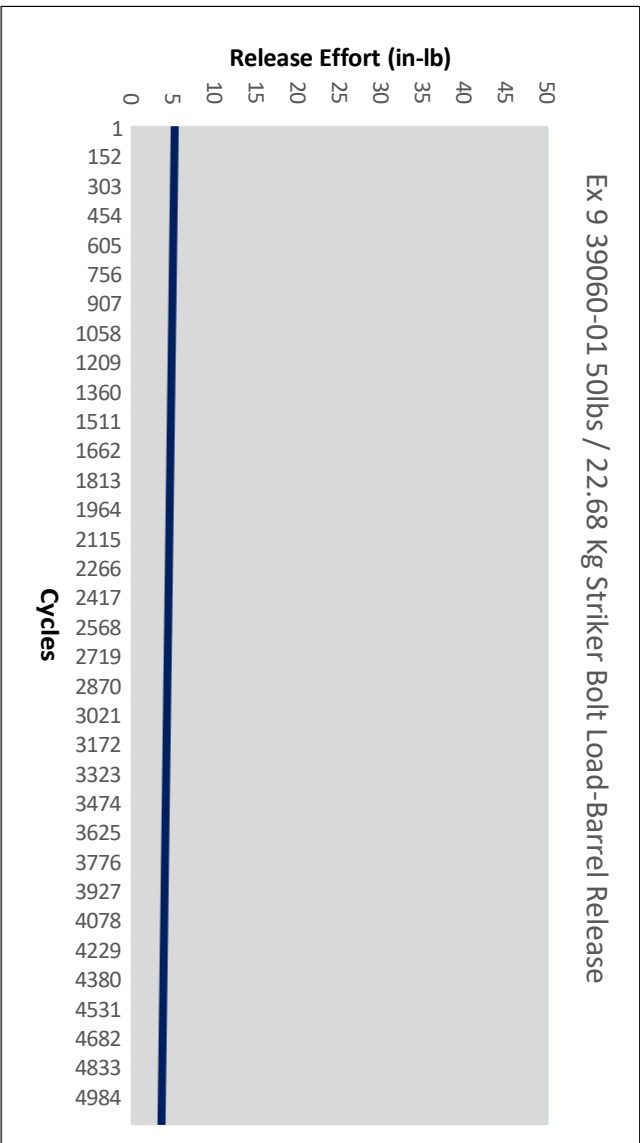

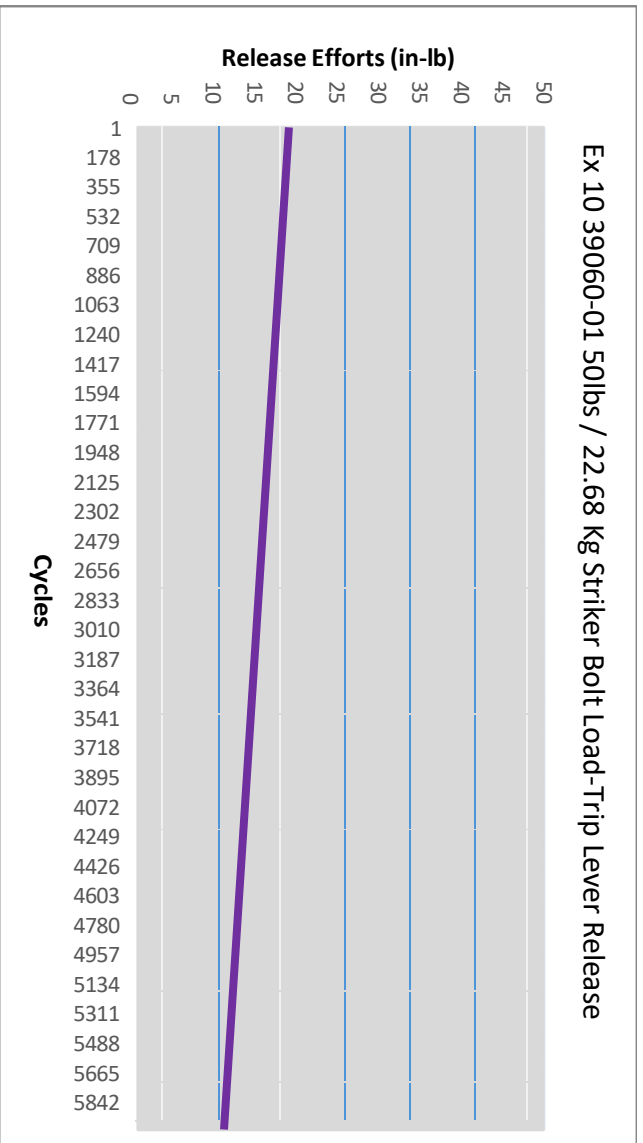
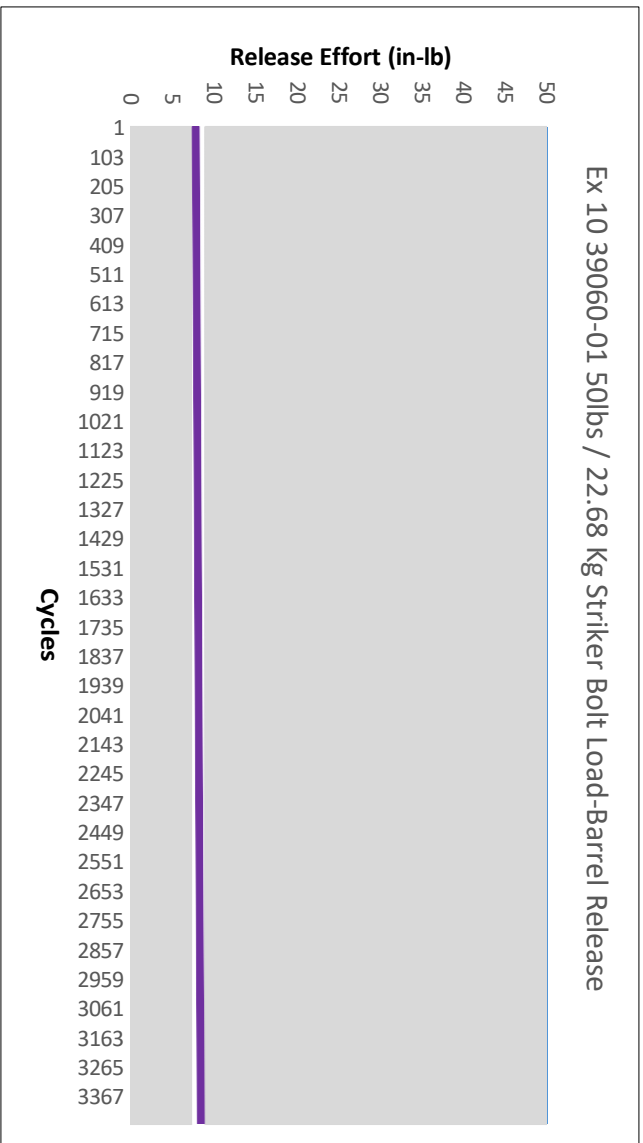

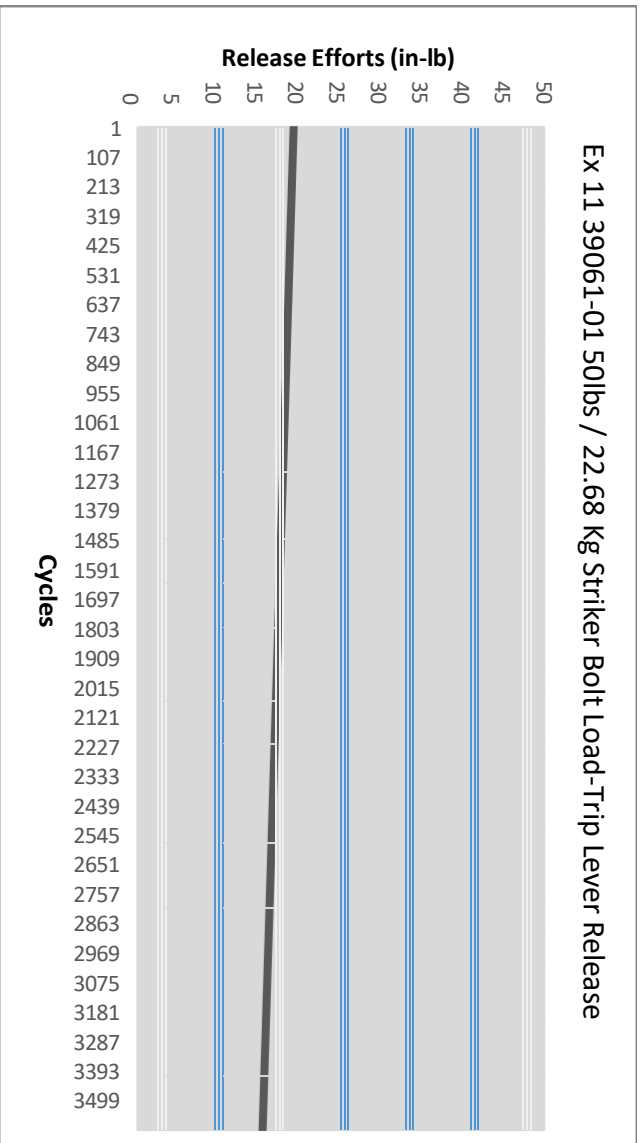
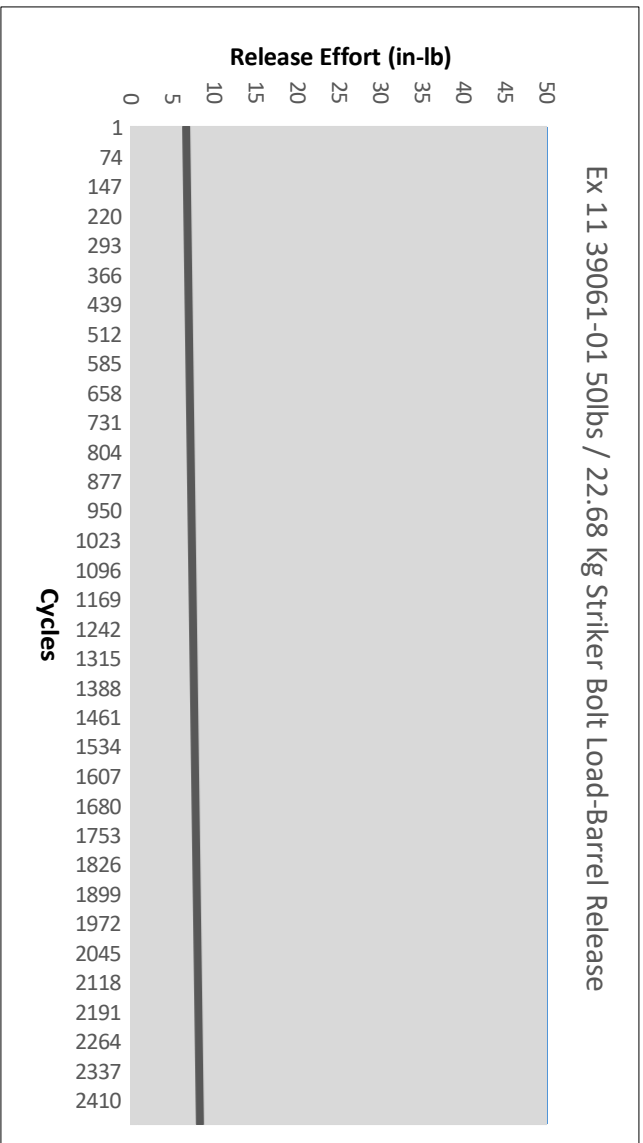

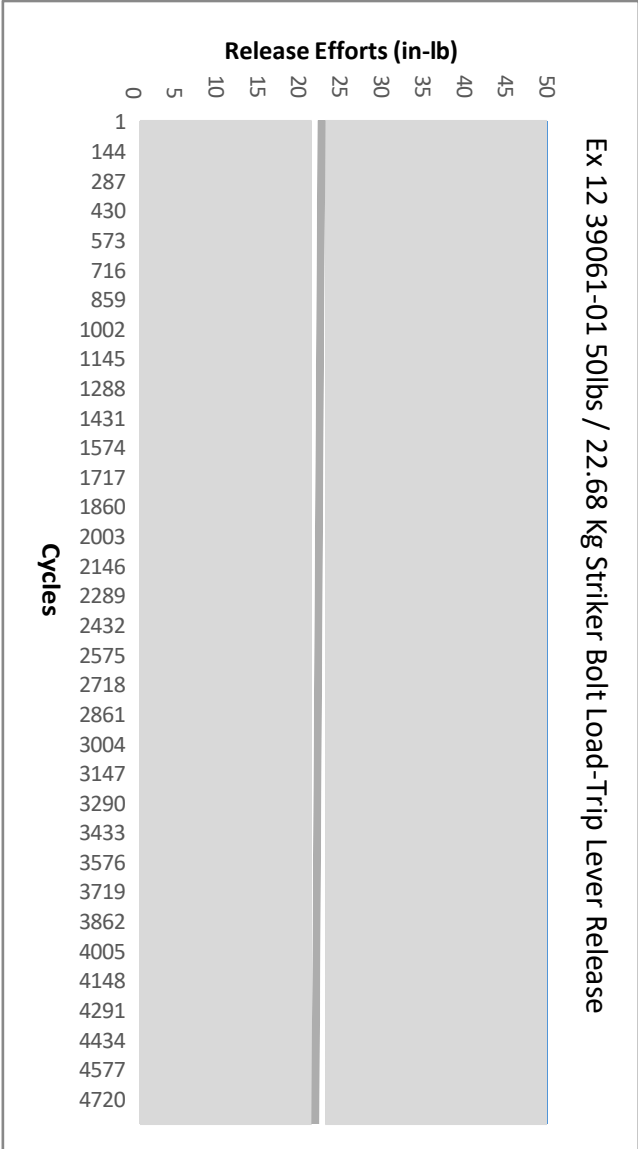
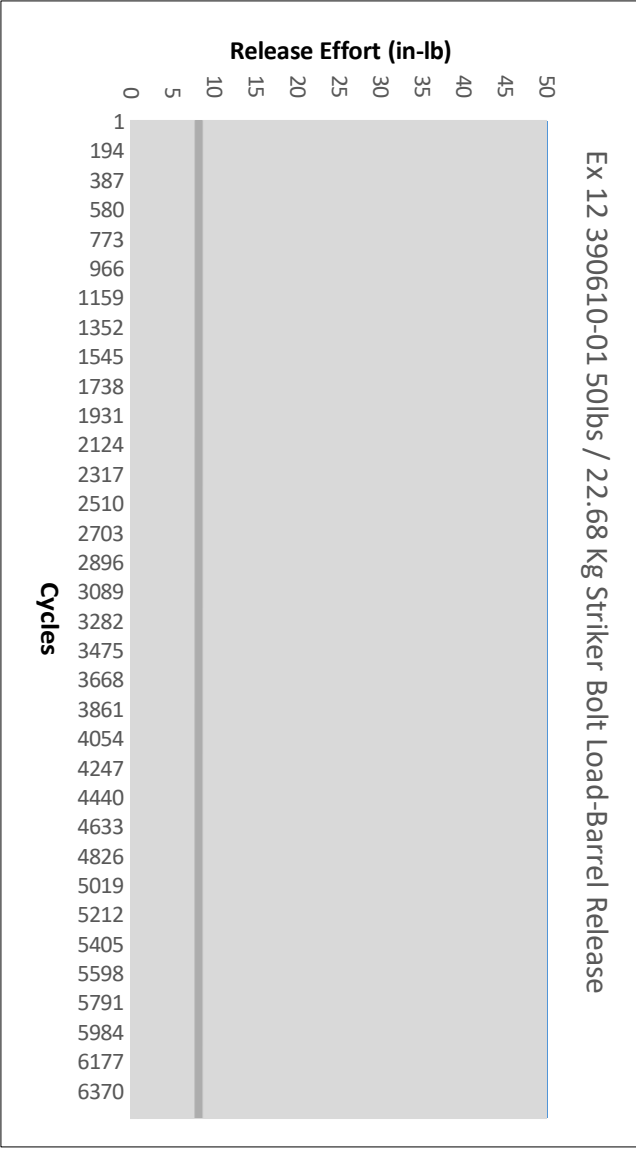

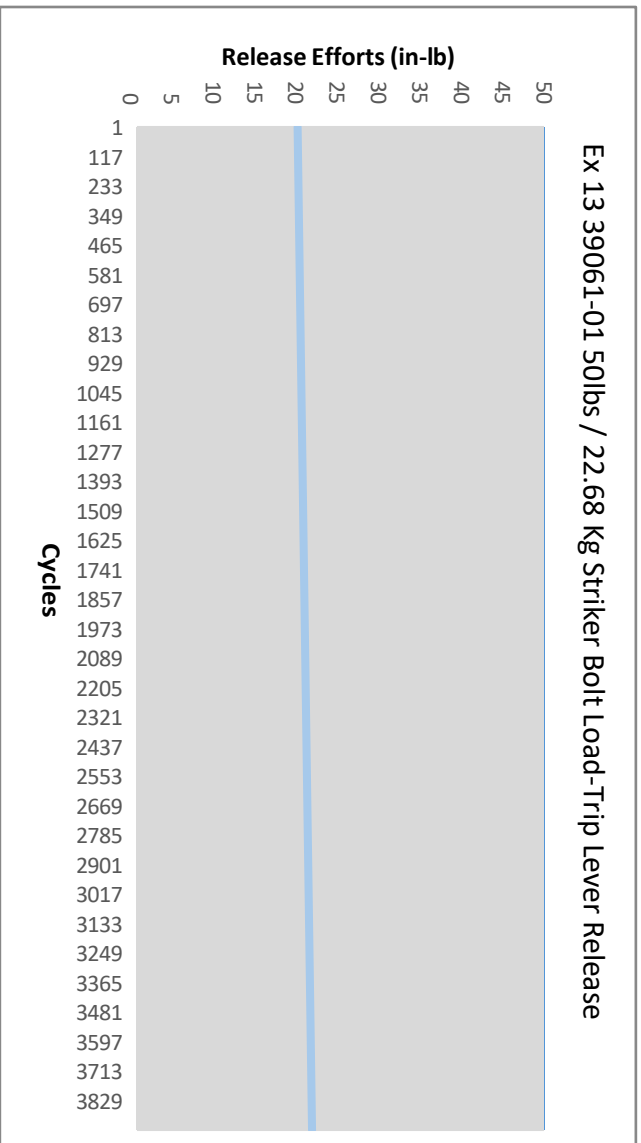
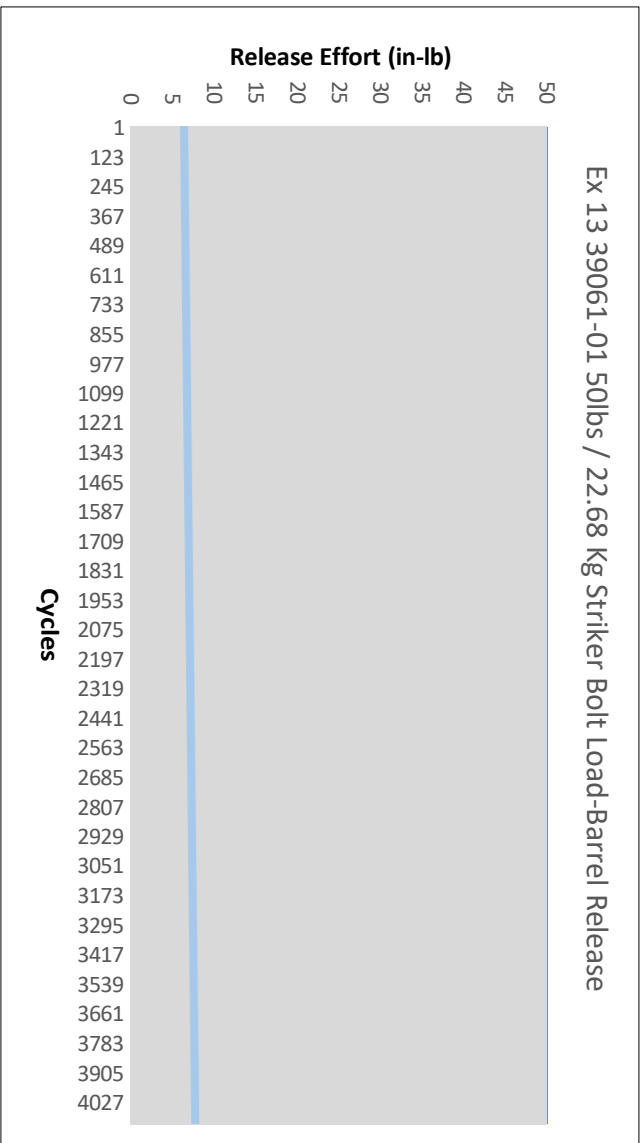

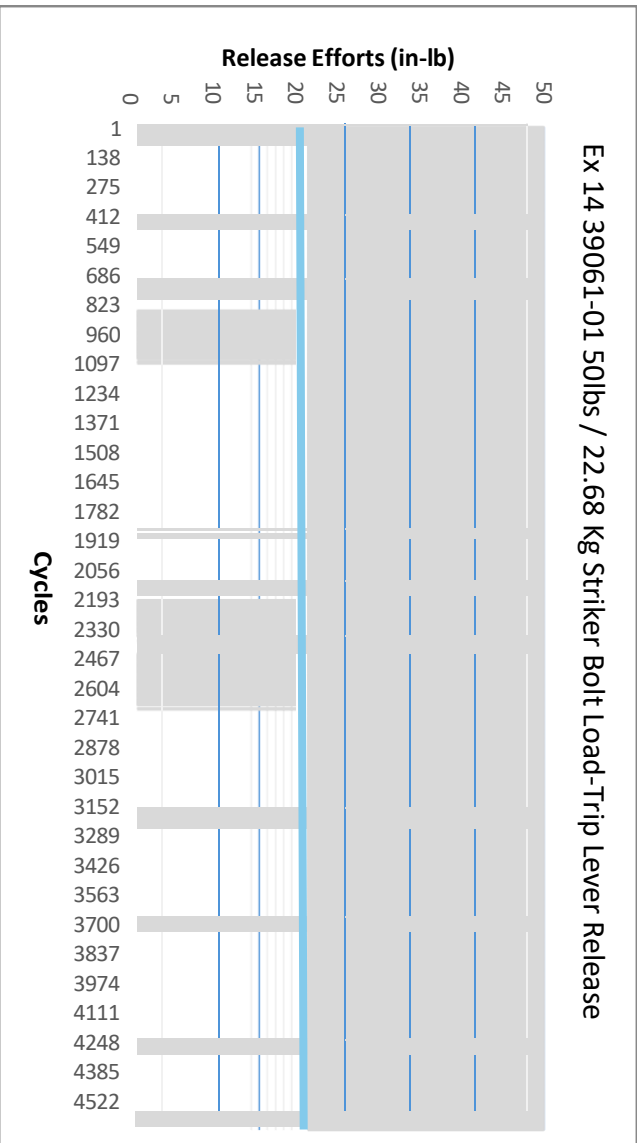
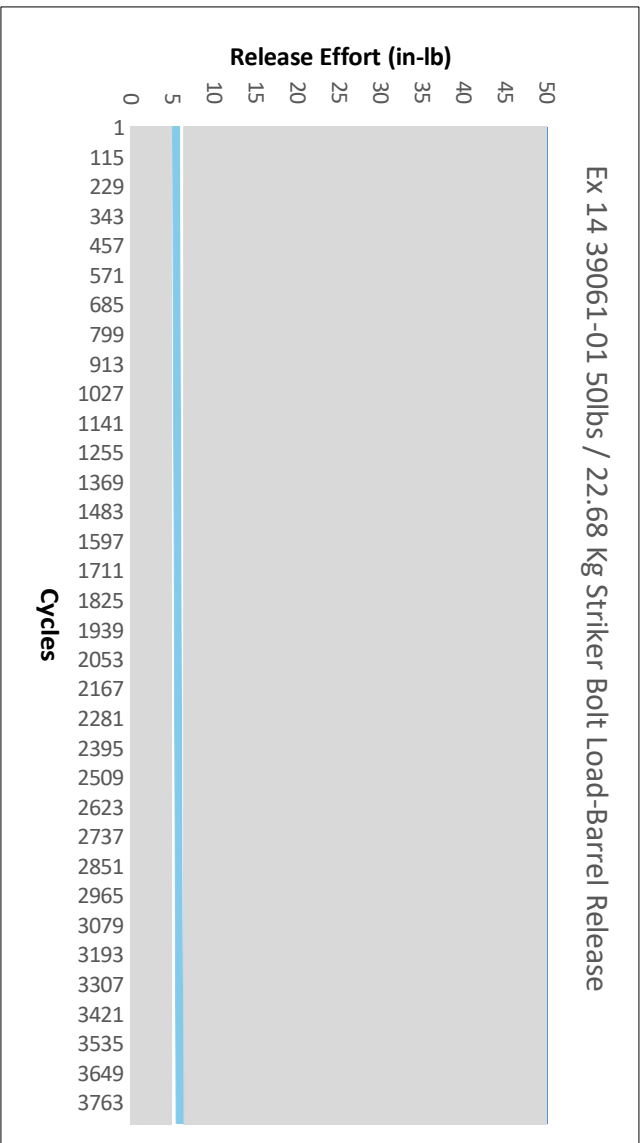

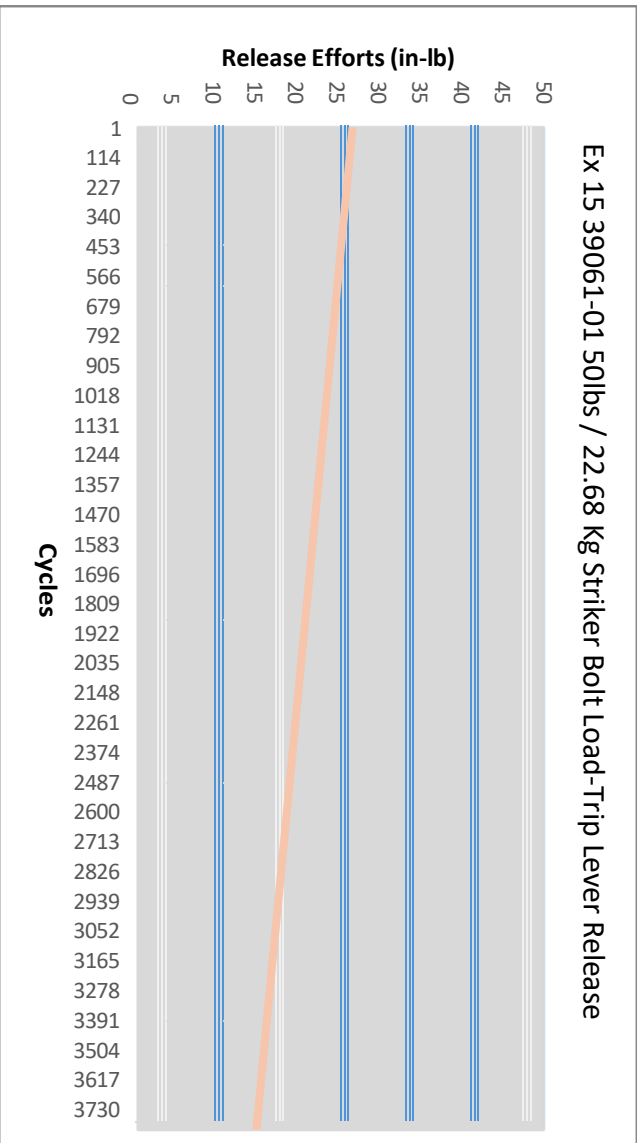
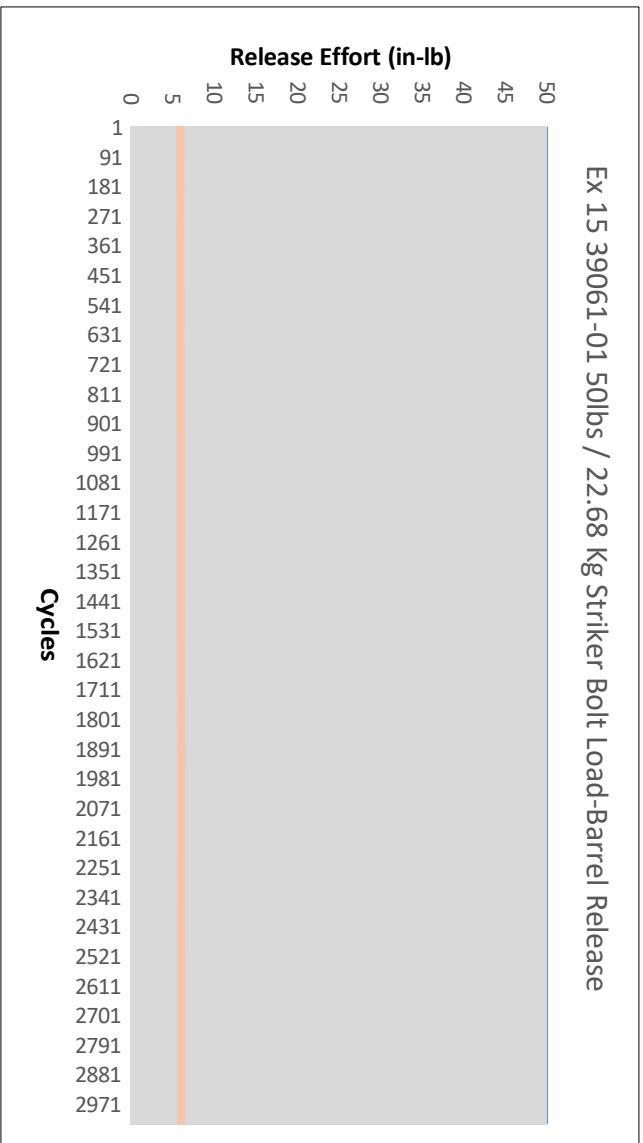

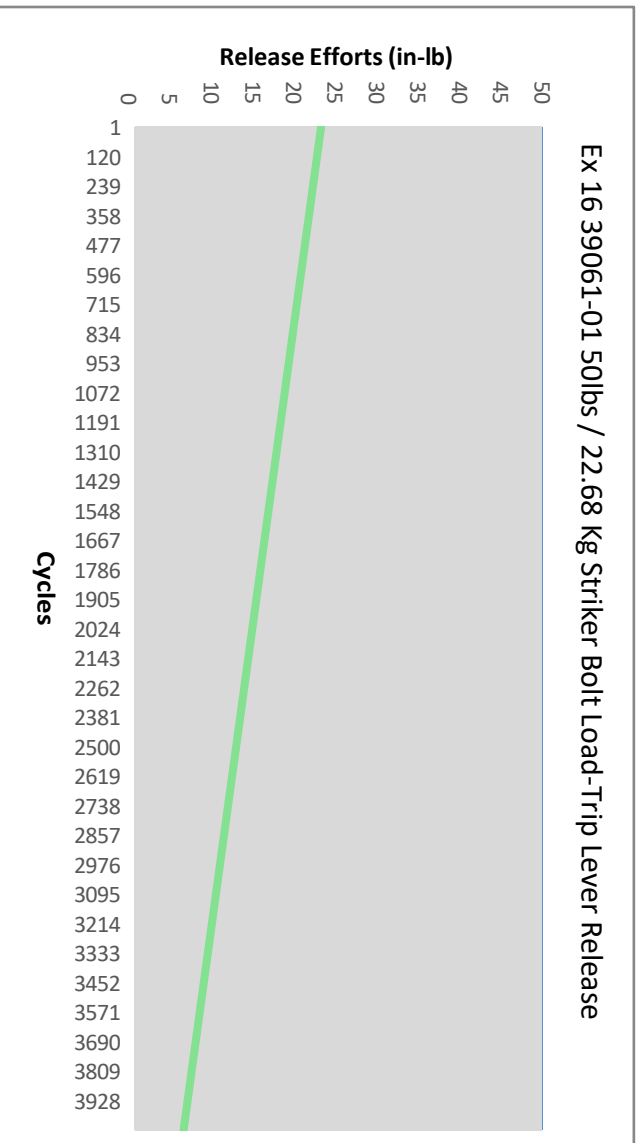
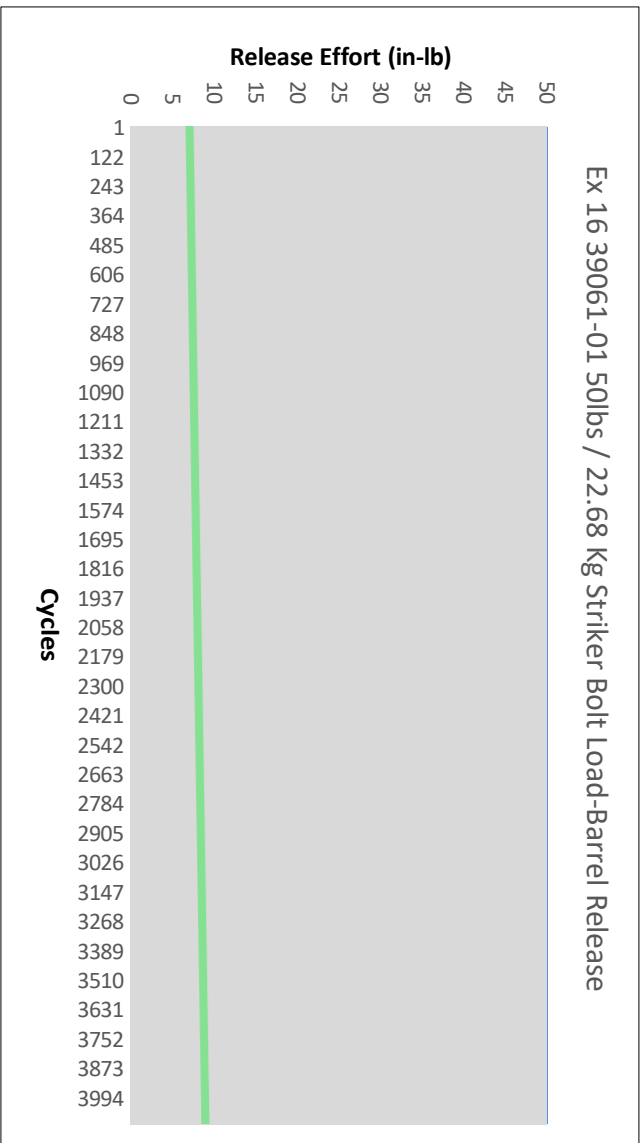

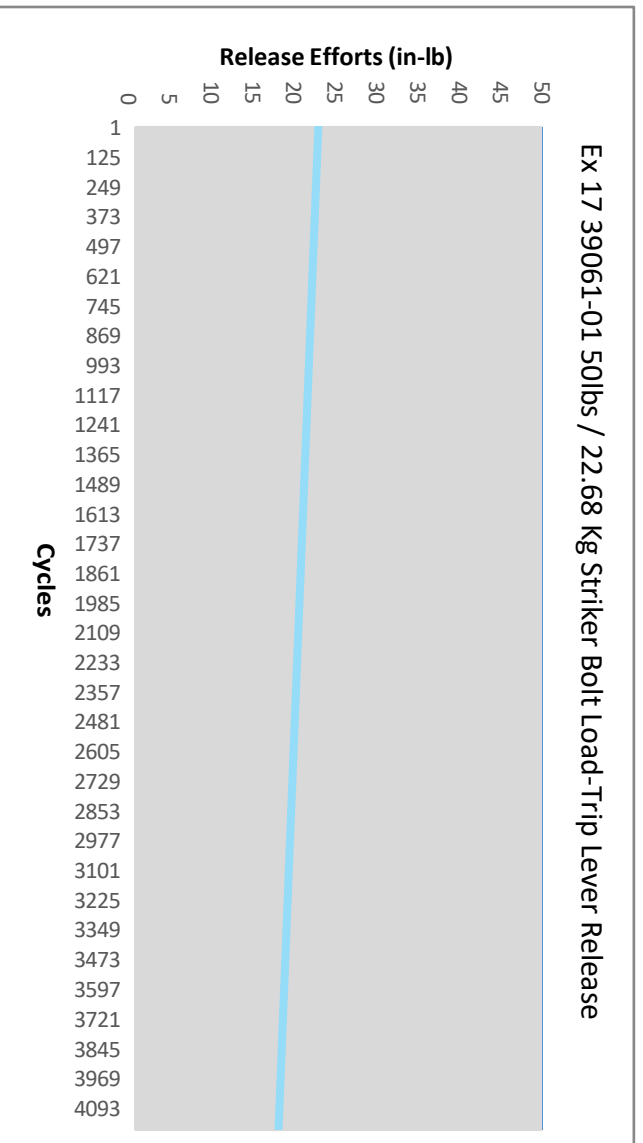
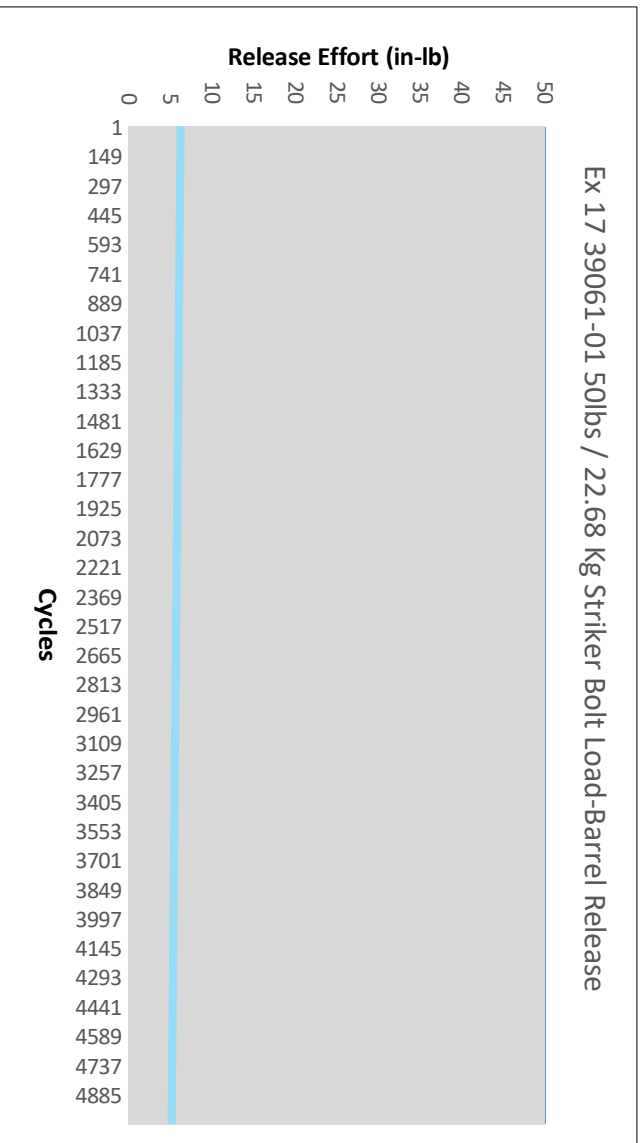

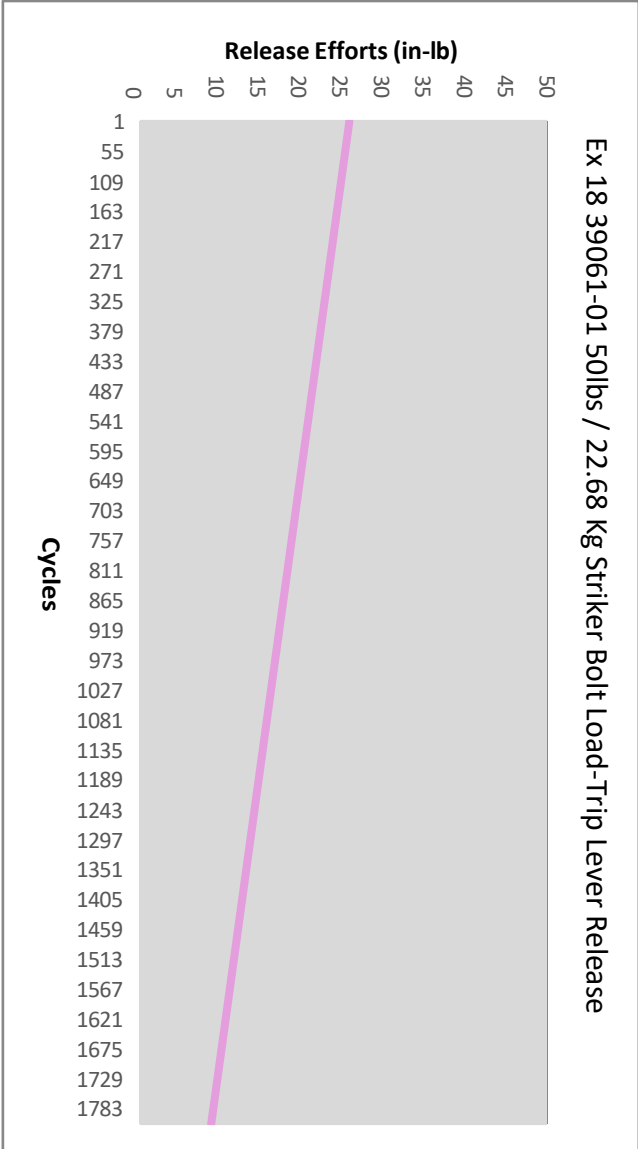
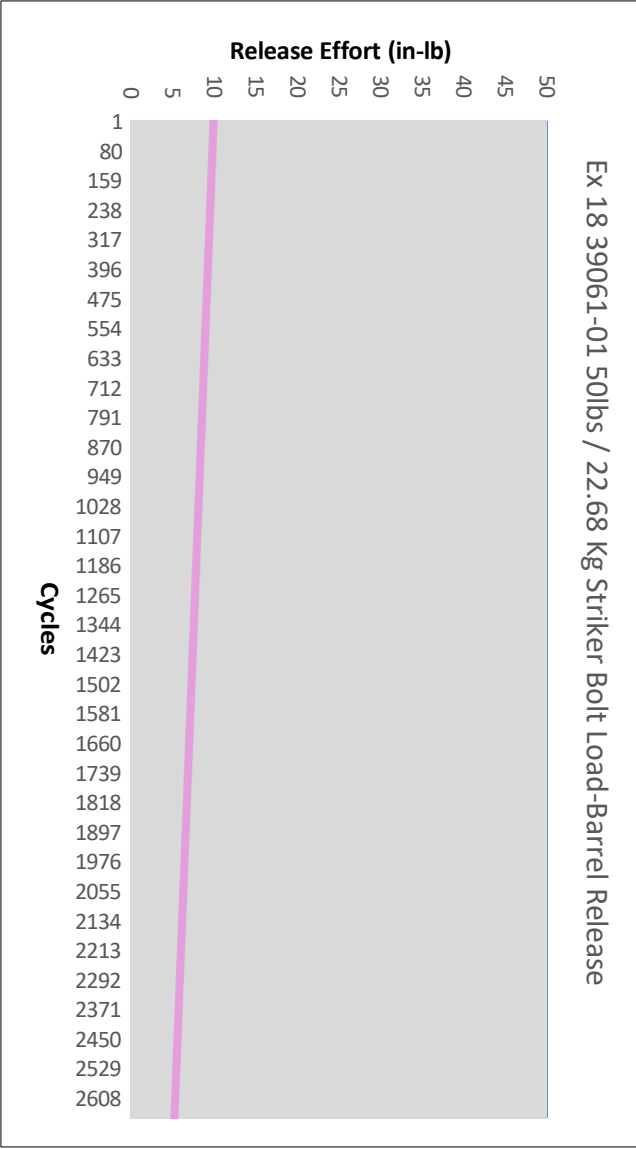

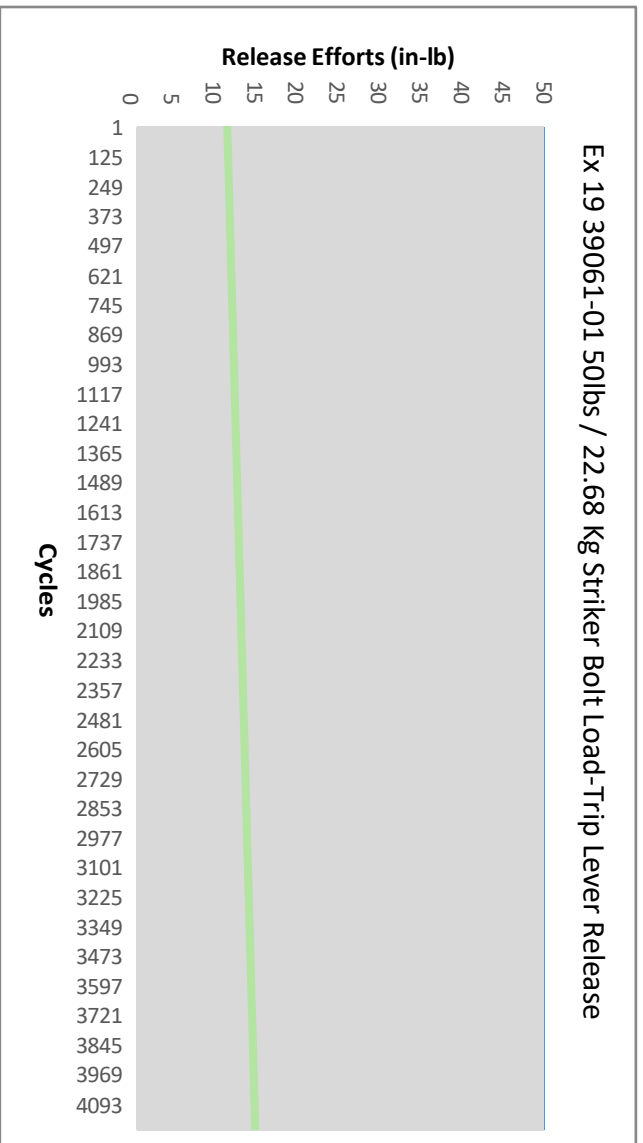
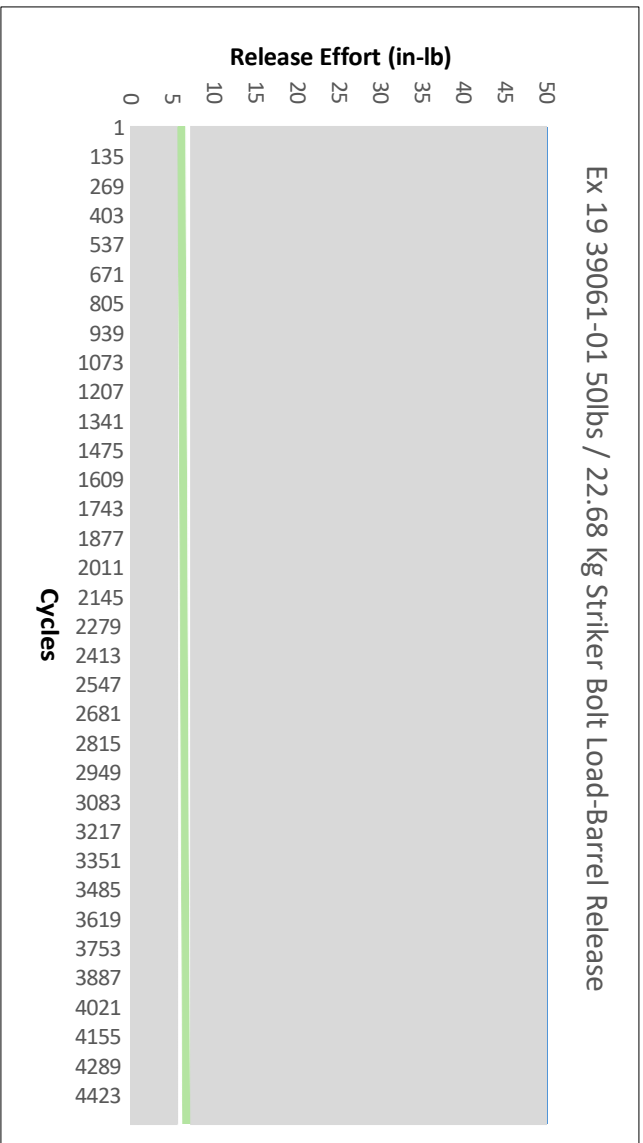

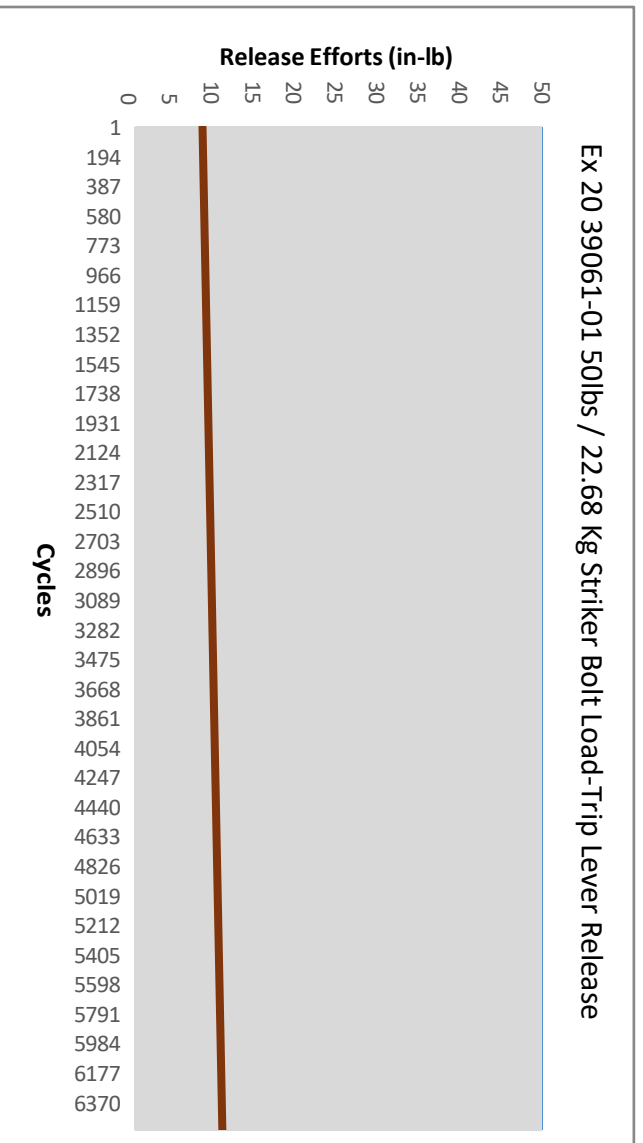
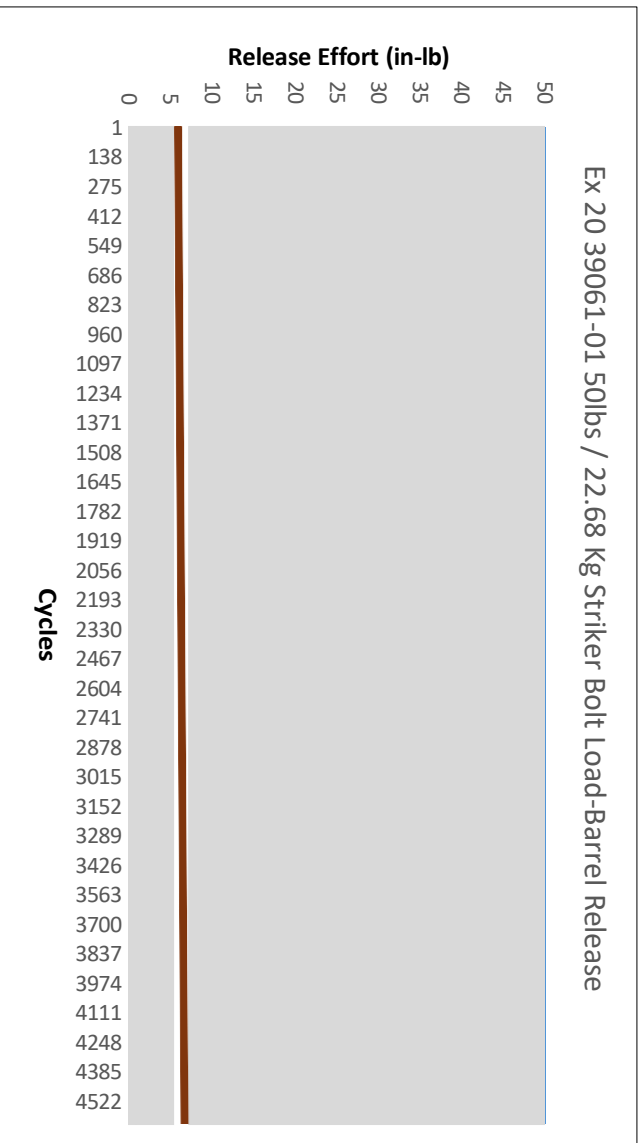

3.5 Technical Product Information

The following ***Technical Product Information*** is available by clicking the links below to direct you to the applicable pages on TriMark Corporation's website. These can also be found under the Products Tab of [TriMark Corporation's](#) home page.

[***Door Hardware Design and Consideration***](#)

[***Strength Guidelines***](#)

[***Loads on Rotary Door Latching***](#)

[***Measuring DCF \(Door Closing Force\) and SBL \(Strike Bolt Load\)***](#)

[***Guidelines for Mounting Torque***](#)

[***Latch and Striker Installation***](#)

[***Finishes***](#)

[***Materials***](#)

[***Lubrication***](#)

[***Glossary of Terms***](#)